

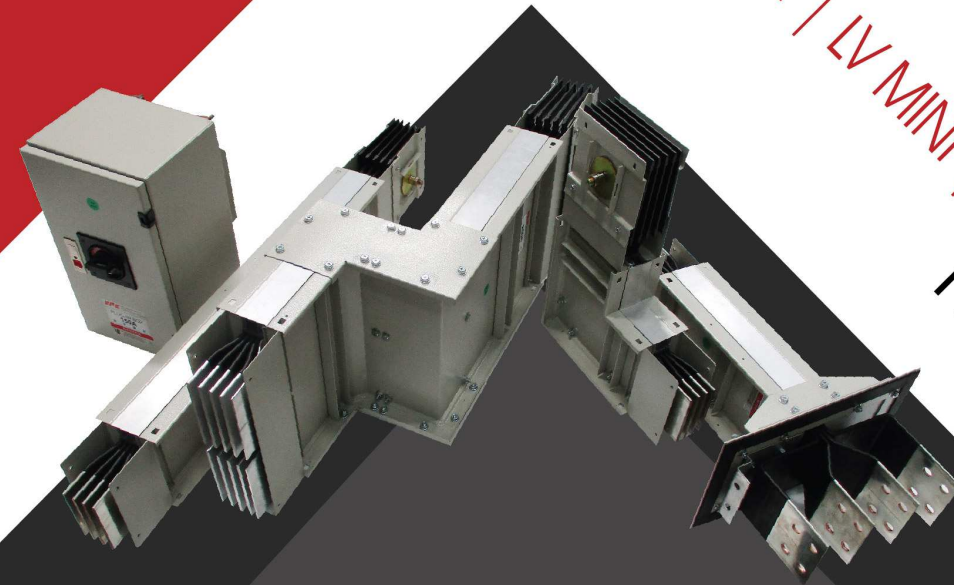

EPE BUSWAY SYSTEM



EPE-SERIES
LV SANDWICH / LV MINI / LV NSPB / MV NSPB
1KV - 36KV



EPE BUSWAY Sdn Bhd
(886581-H)

Our quality policy is one of continuous improvement in the aspects of customer satisfaction, product evolution, efficient operation and workforce development.

Lot 6, Jalan Permata 2, Arab Malaysian Industrial Park,
71800 Nilai, Negeri Sembilan, Malaysia.
Tel : (606) 799 8500 (General Line) Fax : (606) 799 8630
Webpage : www.epemalaysia.com
Email : busway@epeswg.com.my
EPE reserves the right to change the content without prior notice

EPE HISTORY

EPE began as Electrical Power Engineering Sdn. Bhd. in 1972. and has been an iconic name for switchgear and power distribution products in Malaysia and its surrounding regions ever since. EPE has over the years supplied its customers' superior power transmission & distribution requirement, including power solutions.

Being one of the major power suppliers to Malaysian Power Utilities for the last four decades, EPE has also supplied to other utilities overseas such as Zimbabwe Electrical Supply Authority (ZESA), Yemen Public Electricity Co., Dhaka Electrical Supply Co. (DESCO), Fiji Electricity Authority, North Cyprus Electric Authority, FEWA UAE, Al-Sunut Power Plant UAE, DAL Group Atbara Sudan, Safah Power Plant Oman, Al Waab City Kahramaa Qatar, Sheikh Khalifa Sports City Bahrain, and many more. The following milestones are EPE's major events:

1970's

- * EPE began as Electrical Power Engineering Sdn. Bhd.
- * EPE first acquired the technology and technical know-how from Sprecher & Schuh, Switzerland for medium voltage oil circuit breaker and panel.

1980's

- * EPE further expanded it's range of products by acquiring the technology and technical know how from Reyrolle UK/NZ for oil ring main units and Meidensha Japan for vacuum circuit breaker.

1990's

- * EPE ventured into overseas market.
- * EPE developed electrical busway system for power distribution.
- * EPE was awarded contracts for supply of the utility facilities in Zimbabwe, Yemen, Philipines Cyprus and Bangladesh, and supplied to some industrial plants in Vietnam, China, Australia and New Zealand.
- * EPE also participated in commercial sectors such as hotels, residentials, and complexes.
- * EPE expanded its switchgear product range and technology by acquiring Gas Insulated Switchgear (GIS) technology from Japan AE corporation.

2000's

- * EPE continued to expand its business overseas into UAE, Oman, South Africa, Qatar, Sri Lanka, Hong Kong, Turkey, Sudan, Bahrain and as well Singapore.
- * EPE acquired the technology and technical know-how from Lucy Switchgear for its RMU range.

2010's

- * EPE continues to develop better quality and achievement through its R&D with an existing plant in a 6 acres land area.
- * EPE has the potential to achieve a minimum of USD50 million sales annually on electrical switchgear and power distribution products.

TABLE OF CONTENT

	02	▶ Introduction EPE corporate goals Principal business activities
LV busway technical features Perfect balancing joint system	03	
	04	▶ Reliable insulation Plug-in & tap-off power distribution
Quality & testing Standard specification	05	
	06	▶ Busbar configuration
Busway stacking	07	
	08	▶ Housing integral earth Internal earth busbar Busway size & weight
Joint details	09	
	10	▶ Feeder busduct Plug-in busduct
Horizontal elbow Vertical elbow	11	
	12	▶ Combination elbow Vertical tee
Horizontal tee Vertical offset	13	
	14	▶ Horizontal offset Reducer
Flange end Flange end Connection	15	
	16	▶ Flange end box Expansion box
Plug-in box & Tap-off box Wall Flange	17	
	18	▶ Horizontal hanger Spring hanger / Fixed Hanger
End closure Flexible Conductor	19	
	20	▶ Electrical Characteristics For Copper & Aluminium Conductor
HV Busway Technical Specification	21	
	22	▶ NSPB LV Type Busway Technical Specification
EPE Mini Busway	23	
	24	▶ Fire Rated Busway
Quality Assurance	25	

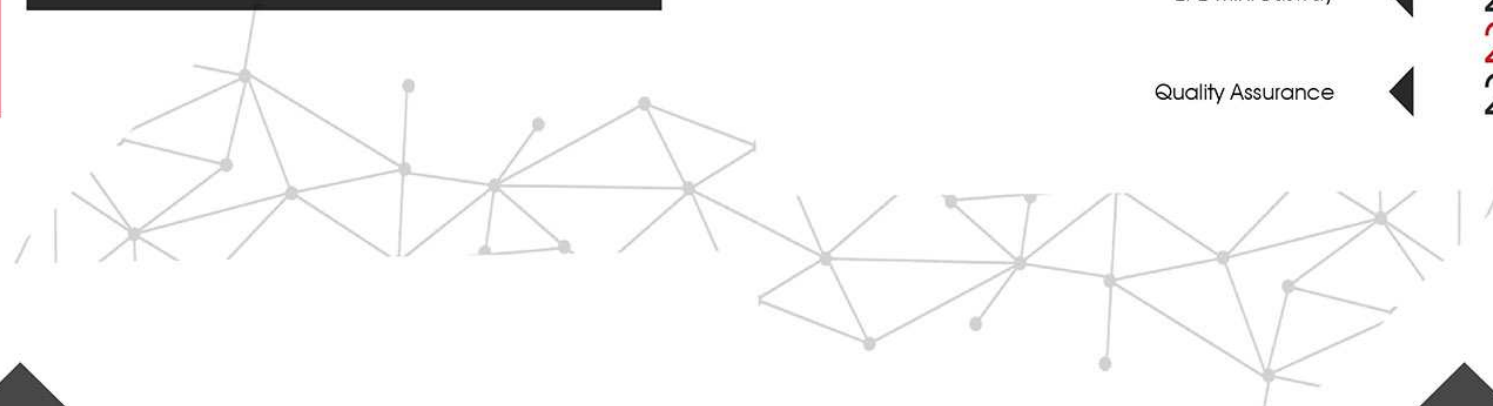

INTRODUCTION

Busway system is widely acceptable and installed in this modern electrical industry for reliable distribution. It has been recognized in recent years due to rapid economic growth and its demands. It has far better features compared with cable distribution, with details as follow :-

- (1) Low voltage drop & impedance
- (2) Flexibility in power distribution & expansion
- (3) Easy installation & maintenance
- (4) Less space required & compact design
- (5) More rigid & stronger enclosure
- (6) Higher short circuit withstand strength
- (7) Longer life span

EPE Busway has been developed to cater the high demands of busway industry market with the following advantages / features of LV busway :-

- (1) Unique busway construction of compact type design with combined galvanized steel and Aluminium heat sink channel
- (2) Perfect balancing joint system
- (3) Easy installation
- (4) Reliable insulation with good thermal conductivity
- (5) Easy & safer plug-in process for power distribution
- (6) Higher operating temperature & short circuit withstand strength
- (7) Production & process strictly under stringent quality control
- (8) On-time delivery
- (9) Prompt response after sales & services



For MV busway, EPE has developed 3 categories of its kind, which are :-

- (1) NSPB - Non-Segregated Phase Busway
- (2) SPB - Segregated Phase Busway
- (3) IPB - Isolated Phase Busway

EPE CORPORATE GOALS

- (1) Explore and strengthen our presence in business accompanying electrical infrastructure distribution & services
- (2) Continuous improvement for manufacturing efficiency and productivity
- (3) Enhance competencies through manpower development and training

PRINCIPAL BUSINESS ACTIVITIES

- (1) Design and manufacture of Medium Voltage & Low Voltage Busway System
- (2) Provide high efficiency and reliable electrical distribution
- (3) Provide fast response after sales and services
- (4) Operation & maintenance services
- (5) Retrofitting and upgrading services



LV BUSWAY TECHNICAL FEATURES

Busway Construction

EPE Busway has an unique housing construction based on compact type design, combining 1.6mm thickness of galvanized steel (at both sides) with epoxy powder coating and Aluminium heat sink channel (at top & bottom sides), in order to provide the following advantages :-

- (1) Better heat dissipating (from the Aluminium heat sink channel)
- (2) Grounding system (supported by the Aluminium heat sink channel with Aluminium joint cover)
- (3) EMF elimination (by the Aluminium heat sink channel)
- (4) Higher mechanical withstand strength (achieved by galvanized steel)
- (5) Corrosion free (achieved by epoxy coating & Aluminium heat sink channel)

The busway design & construction are based on IEC61439-6, standard and other equivalent Standards.

The construction also provides minimum ingress of protection (IP) of IP54 and maximum up to IP66 based on IEC61529, with also flame propagation protection (based on IEC61332-3) as a basic feature for every busway risers. It also can be designed for fire rated based on IEC60331 & BS6387 Standards upon request.

Perfect Balancing Joint System

EPE Busway incorporated the bridge type joint with feature of balancing the current capacity at each of the joint sections (for double & triple stack busways).

This type of joint which based on single bolt design, featuring an insulated bolt with maintenance free nut (MF nut / double headed nut) & Belleville washer will ease the installation work & easy maintenance.

The MF nut is designed such a way that it will shear off automatically at a torque of 160~180Nm during tightening.

Besides, this balancing joint system is also designed for higher surface contact area on the conductors with a perfect grip by the Belleville washer which provides low resistance & temperature. It is also easy to detach & install during maintenance without removing any adjacent busway feeders.



RELIABLE INSULATION

EPE Busway has a superior insulation for its entire conductor made from high grade material insulation of Class F 155 deg C.

The insulation process is unique by insulating the conductor through an extrusion machine.

This process will automatically eliminate any air gap formed between the insulation and conductor. This type of insulation has been tested based on IEC 61439-6.

The advantages of the insulation are as follows :-

- (1) Good thermal conductivity
- (2) Withstand thermal heat shock
- (3) Water & chemical resistant
- (4) Withstand electrical glitches & spikes
- (5) Withstand mechanical strength against impact
- (6) Able to expand & contract during peak & off-peak operations
- (7) Non-toxic & environmental friendly
(incorporation with Green Technology design)

PLUG IN & TAP OFF POWER DISTRIBUTION

EPE Busway provides wide range of power distribution up to 2000A, with built in circuit breakers (MCCB).

There are 2 types of power distribution on EPE Busway, details as follow :-

- a) Plug In Type - breaker rated up to 400A
- b) Tap Off Type (Bolted Type) - breaker rated above 400A and up to 2000A

There is an interlocking system at the plug in unit for safety purpose; to prevent any removal of the unit upon the unit is in operation. Furthermore, the copper clips of the plug-in unit are equipped with spring clamps to provide proper attachment / fixing into the plug in opening's conductors. Besides, the copper clips are also protected by an insulation block Class C 200 deg C to prevent any flashover.

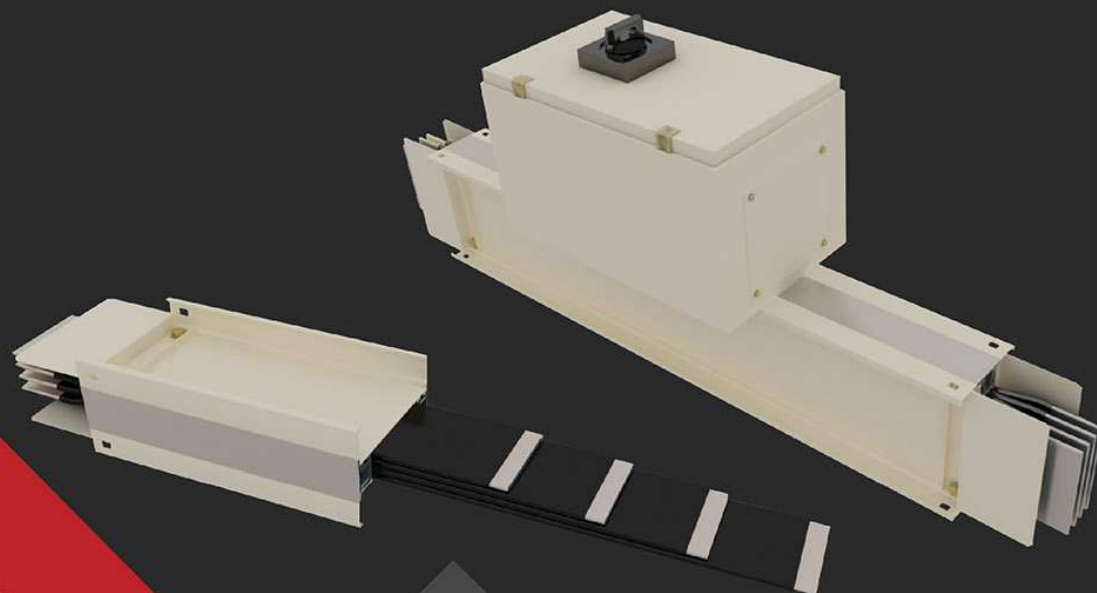

QUALITY & TESTING

All EPE Busway feeders will be tested during internal factory test and verified by qualified QC personnel, before any shipment or delivery to site.

The factory test consists of 2 major tests - insulation resistance & withstands voltage. It will be documented and presented to the project owner based on each shipment / delivery.

EPE Busway is also tested and verified by third party authorities such as ASTA, UL, etc based on IEC 61439-6 standard.

STANDARD SPECIFICATION

Type of busway construction : Compact design

Standard : IEC61439-6 & other equivalent.

System configuration : 1P2W, 1P3W, 3P3W, 3P3W+E, 3P4W, 3P4W+E, 3P5W (200%N), 3P5W+E (200%N)

Ingress of protection (IP) rating : IP54 to IP66

Rated AC voltage : Up to 1000V

Rated DC voltage : Up to 1000V

Frequency : 50Hz / 60Hz

Current rating : Up to 6300A

Conductor : Copper & Aluminium

Service temperature : Up to 50 deg C
(full load operation without de-rating)

Short circuit capacity : up to 150kA

Plug in type distribution : Up to 400A

Tap off type distribution : 500A to 2000A



BUSWAY STACKING

EPE Busway provides single stack system up to 2500A Copper and 2000A Aluminium, double stack system up to 5000A Copper and 4000A Aluminium, and triple stack system up to 6300A Copper and Aluminium.

Single Stack

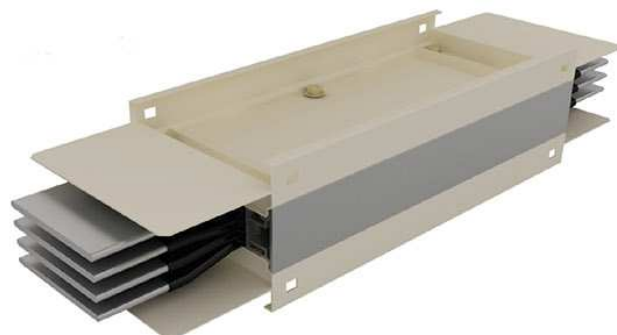

Double Stack

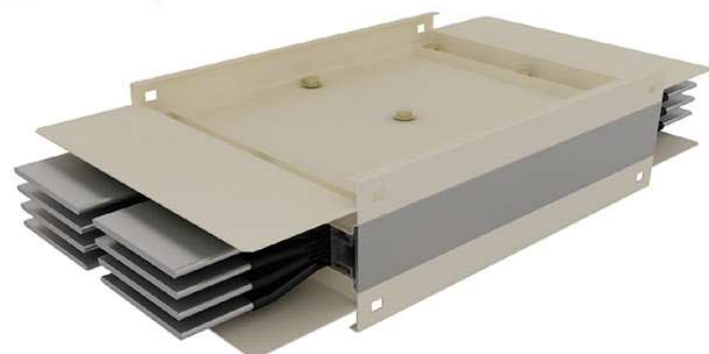

Triple Stack

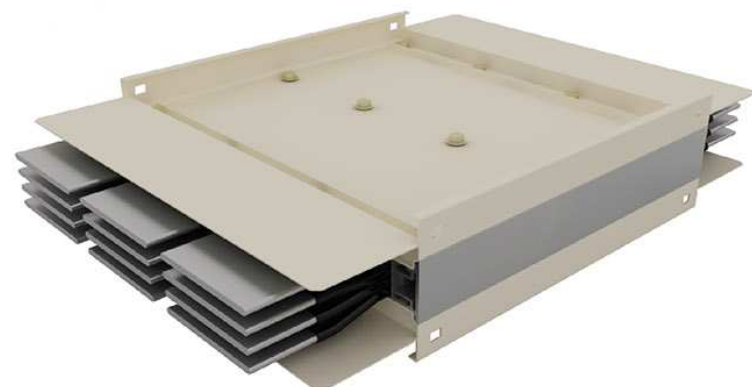

3P3W

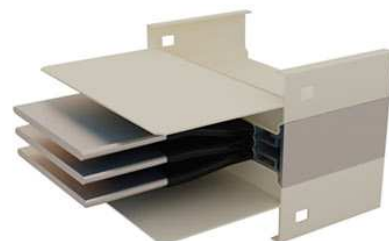

3P4W

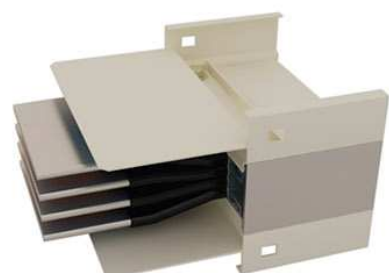

3P5W (200%N)

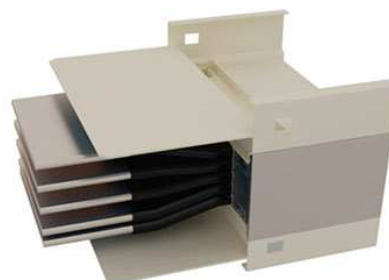

3P3W + E



3P4W + E

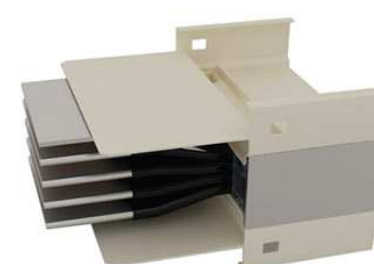

3P5W + E (200%N)

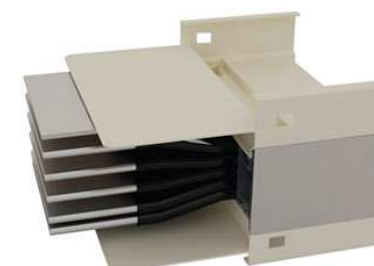

BUSBAR CONFIGURATION

EPE Busway provides 3P3W, 3P4W and 3P5W(200%N) compactly assembled with Aluminium heat sink channel. Additional 50% earth busbar can be applied as extra requirement.

HOUSING INTEGRAL EARTH / INTERNAL EARTH BUSBAR

EPE Busway housing is an integral earth. For extra requirement, EPE Busway also offers internal earth busbar with 50% rated of the capacity of the phase busbar as shown below.

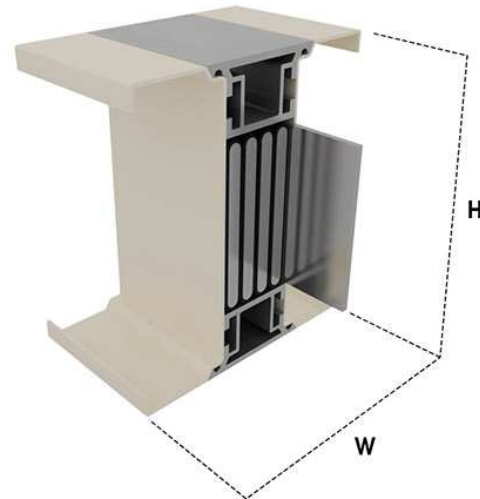

BUSWAY SIZE AND WEIGHT

Item	Ampere (A)	Copper Size (mm)	Busway Width W (mm)	Busway Height H (mm)	Busway Weight (kg/m)			
					3P3W	3P3W+E	3P4W	3P4W+E
1	400A	1 x 6 x 30	125	95	16	18	19	20
2	630A	1 x 6 x 40	125	105	18	20	21	23
3	800A	1 x 6 x 50	125	115	21	23	24	27
4	1000A	1 x 6 x 75	125	140	26	29	31	34
5	1250A	1 x 6 x 80	125	145	27	30	32	35
6	1500A	1 x 6 x 100	125	165	31	35	38	41
7	1600A	1 x 6 x 125	125	190	36	41	44	50
8	2000A	1 x 6 x 150	125	215	42	49	52	59
9	2500A	1 x 6 x 200	125	265	53	60	67	73
10	3200A	2 x 6 x 125	125	335	64	73	80	90
11	4000A	2 x 6 x 150	125	385	75	88	95	109
12	5000A	2 x 6 x 200	125	485	92	107	117	133
13	5500A	3 x 6 x 150	125	555	109	128	138	160
14	6300A	3 x 6 x 160	125	585	126	144	160	179

Item	Ampere (A)	Aluminium Size (mm)	Busway Width W (mm)	Busway Height H (mm)	Busway Weight (kg/m)			
					3P3W	3P3W+E	3P4W	3P4W+E
1	400A	1 x 6 x 40	125	105	15	15	15	16
2	630A	1 x 6 x 50	125	115	16	16	16	17
3	800A	1 x 6 x 75	125	140	18	19	20	20
4	1000A	1 x 6 x 100	125	165	21	22	22	23
5	1250A	1 x 6 x 125	125	190	23	24	25	26
6	1600A	1 x 6 x 150	125	215	27	28	29	30
7	2000A	1 x 6 x 200	125	265	33	35	36	38
8	2500A	2 x 6 x 125	125	335	38	40	42	44
9	3200A	2 x 6 x 150	125	385	45	48	50	52
10	4000A	2 x 6 x 200	125	485	58	61	64	68
11	5000A	3 x 6 x 200	125	705	83	88	92	97
12	6300A	3 x 6 x 230	125	795	87	93	98	104

JOINT DETAILS

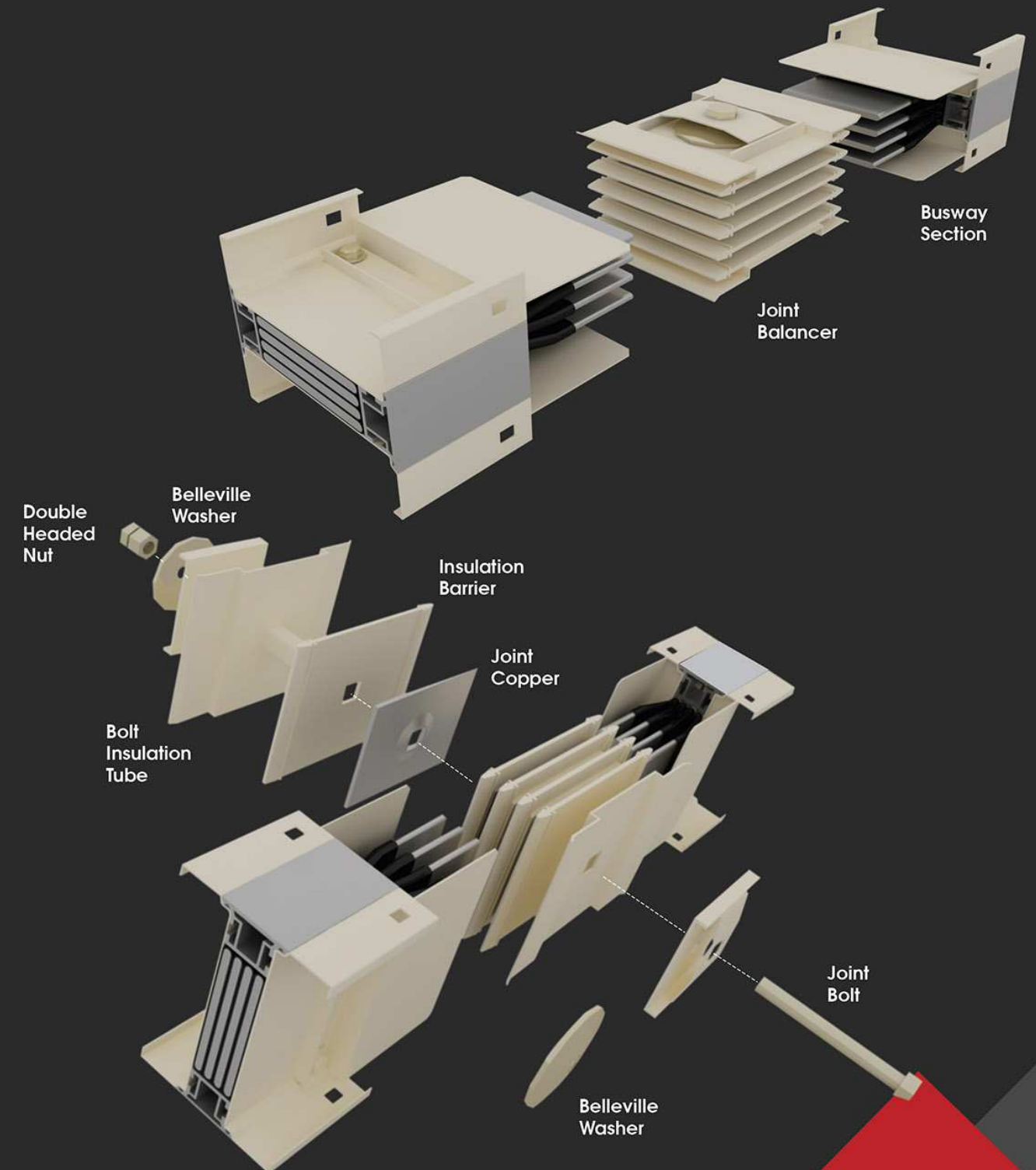

FEEDER & PLUG-IN BUSWAY

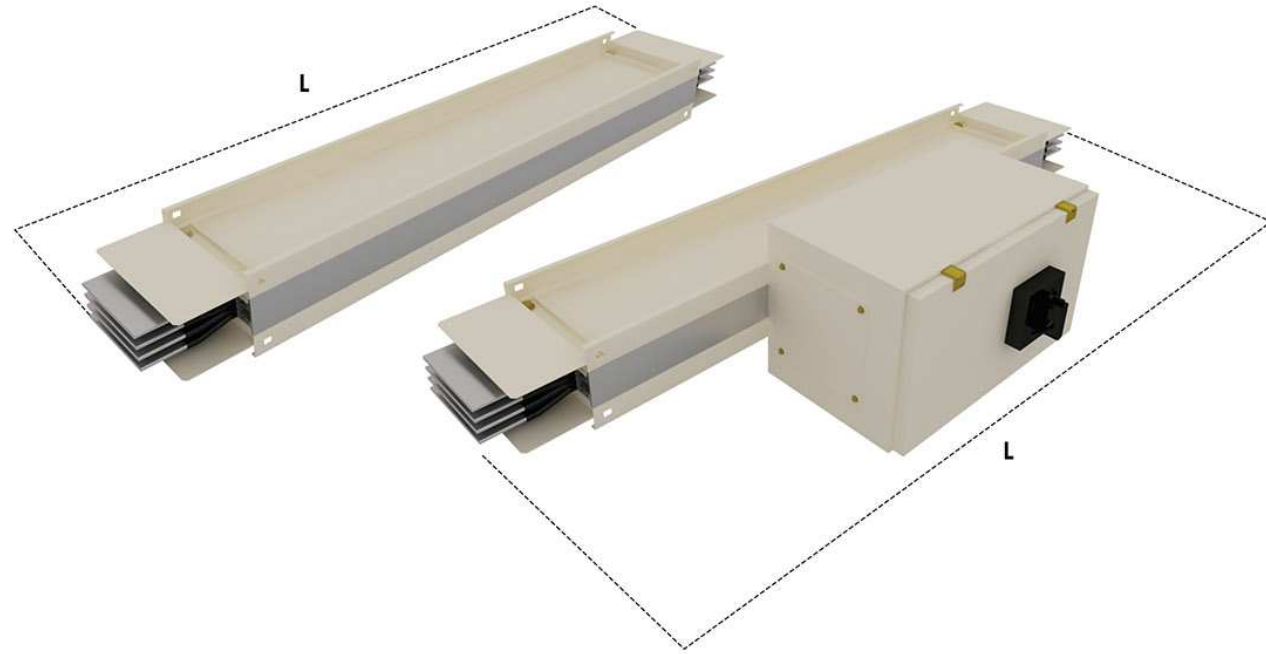

Item	Ampere (A)	Copper Size (mm)	Feeder Busway		Plug-in Busway	
			Minimum L (mm)	Maximum L (mm)	Minimum L (mm)	Maximum L (mm)
1	400A	1 x 6 x 30	450	3000	1000	3000
2	630A	1 x 6 x 40	450	3000	1000	3000
3	800A	1 x 6 x 50	450	3000	1000	3000
4	1000A	1 x 6 x 75	450	3000	1000	3000
5	1250A	1 x 6 x 80	450	3000	1000	3000
6	1500A	1 x 6 x 100	450	3000	1000	3000
7	1600A	1 x 6 x 125	450	3000	1000	3000
8	2000A	1 x 6 x 150	450	3000	1000	3000
9	2500A	1 x 6 x 200	450	3000	1000	3000
10	3200A	2 x 6 x 125	450	3000	1000	3000
11	4000A	2 x 6 x 150	450	3000	1000	3000
12	5000A	2 x 6 x 200	450	3000	1000	3000
13	5500A	3 x 6 x 150	450	3000	1000	3000
14	6300A	3 x 6 x 160	450	3000	1000	3000

Item	Ampere (A)	Aluminium Size (mm)	Feeder Busway		Plug-in Busway	
			Minimum L (mm)	Maximum L (mm)	Minimum L (mm)	Maximum L (mm)
1	400A	1 x 6 x 40	450	3000	1000	3000
2	630A	1 x 6 x 50	450	3000	1000	3000
3	800A	1 x 6 x 75	450	3000	1000	3000
4	1000A	1 x 6 x 100	450	3000	1000	3000
5	1250A	1 x 6 x 125	450	3000	1000	3000
6	1600A	1 x 6 x 150	450	3000	1000	3000
7	2000A	1 x 6 x 200	450	3000	1000	3000
8	2500A	2 x 6 x 125	450	3000	1000	3000
9	3200A	2 x 6 x 150	450	3000	1000	3000
10	4000A	2 x 6 x 200	450	3000	1000	3000
11	5000A	3 x 6 x 200	450	3000	1000	3000
12	6300A	3 x 6 x 230	450	3000	1000	3000

HORIZONTAL ELBOW

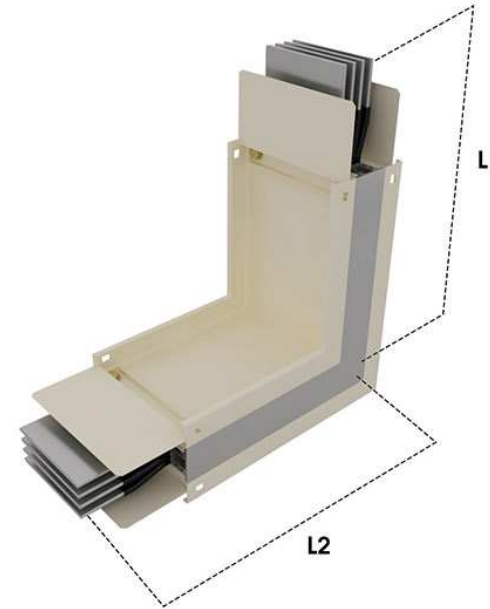

Item	Ampere (A)	Copper Size (mm)	Horizontal Elbow L1 (mm) x L2 (mm)
1	400A	1 x 6 x 30	400 x 400
2	630A	1 x 6 x 40	400 x 400
3	800A	1 x 6 x 50	400 x 400
4	1000A	1 x 6 x 75	400 x 400
5	1250A	1 x 6 x 80	400 x 400
6	1500A	1 x 6 x 100	400 x 400
7	1600A	1 x 6 x 125	400 x 400
8	2000A	1 x 6 x 150	400 x 400
9	2500A	1 x 6 x 200	400 x 400
10	3200A	2 x 6 x 125	400 x 400
11	4000A	2 x 6 x 150	400 x 400
12	5000A	2 x 6 x 200	400 x 400
13	5500A	3 x 6 x 150	400 x 400
14	6300A	3 x 6 x 160	400 x 400

Item	Ampere (A)	Aluminium Size (mm)	Horizontal Elbow L1 (mm) x L2 (mm)
1	400A	1 x 6 x 40	400 x 400
2	630A	1 x 6 x 50	400 x 400
3	800A	1 x 6 x 75	400 x 400
4	1000A	1 x 6 x 100	400 x 400
5	1250A	1 x 6 x 125	400 x 400
6	1600A	1 x 6 x 150	400 x 400
7	2000A	1 x 6 x 200	400 x 400
8	2500A	2 x 6 x 125	400 x 400
9	3200A	2 x 6 x 150	400 x 400
10	4000A	2 x 6 x 200	400 x 400
11	5000A	3 x 6 x 200	400 x 400
12	6300A	3 x 6 x 230	400 x 400

VERTICAL ELBOW

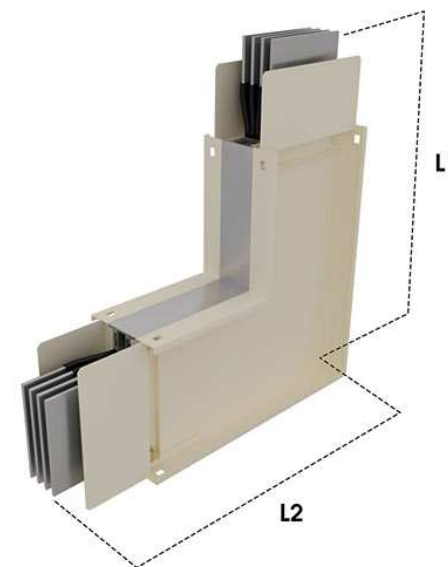

Item	Ampere (A)	Copper Size (mm)	Vertical Elbow L1 (mm) x L2 (mm)
1	400A	1 x 6 x 30	300 x 300
2	630A	1 x 6 x 40	300 x 300
3	800A	1 x 6 x 50	300 x 300
4	1000A	1 x 6 x 75	325 x 325
5	1250A	1 x 6 x 80	325 x 325
6	1500A	1 x 6 x 100	325 x 325
7	1600A	1 x 6 x 125	350 x 350
8	2000A	1 x 6 x 150	350 x 350
9	2500A	1 x 6 x 200	375 x 375
10	3200A	2 x 6 x 125	425 x 425
11	4000A	2 x 6 x 150	450 x 450
12	5000A	2 x 6 x 200	500 x 500
13	5500A	3 x 6 x 150	550 x 550
14	6300A	3 x 6 x 160	600 x 600

Item	Ampere (A)	Aluminium Size (mm)	Vertical Elbow L1 (mm) x L2 (mm)
1	400A	1 x 6 x 40	300 x 300
2	630A	1 x 6 x 50	300 x 300
3	800A	1 x 6 x 75	325 x 325
4	1000A	1 x 6 x 100	325 x 325
5	1250A	1 x 6 x 125	350 x 350
6	1600A	1 x 6 x 150	350 x 350
7	2000A	1 x 6 x 200	375 x 375
8	2500A	2 x 6 x 125	425 x 425
9	3200A	2 x 6 x 150	450 x 450
10	4000A	2 x 6 x 200	500 x 500
11	5000A	3 x 6 x 200	600 x 600
12	6300A	3 x 6 x 230	700 x 700

COMBINATION ELBOW

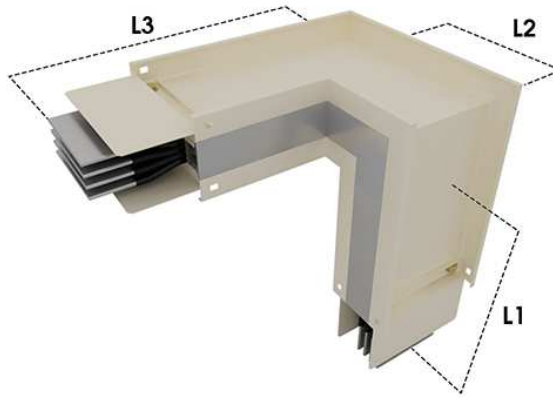

Item	Ampere (A)	Copper Size (mm)	Combination Elbow L1 (mm) x L2 (mm) x L3 (mm)
1	400A	1 x 6 x 30	400 x 250 x 300
2	630A	1 x 6 x 40	400 x 250 x 300
3	800A	1 x 6 x 50	400 x 250 x 300
4	1000A	1 x 6 x 75	400 x 250 x 325
5	1250A	1 x 6 x 80	400 x 250 x 325
6	1500A	1 x 6 x 100	400 x 250 x 325
7	1600A	1 x 6 x 125	400 x 300 x 350
8	2000A	1 x 6 x 150	400 x 300 x 350
9	2500A	1 x 6 x 200	400 x 300 x 375
10	3200A	2 x 6 x 125	400 x 350 x 425
11	4000A	2 x 6 x 150	400 x 400 x 450
12	5000A	2 x 6 x 200	400 x 450 x 550
13	5500A	3 x 6 x 150	400 x 450 x 550
14	6300A	3 x 6 x 160	400 x 500 x 600

Item	Ampere (A)	Aluminium Size (mm)	Combination Elbow L1 (mm) x L2 (mm) x L3 (mm)
1	400A	1 x 6 x 40	400 x 250 x 300
2	630A	1 x 6 x 50	400 x 250 x 300
3	800A	1 x 6 x 75	400 x 250 x 325
4	1000A	1 x 6 x 100	400 x 250 x 325
5	1250A	1 x 6 x 125	400 x 300 x 350
6	1600A	1 x 6 x 150	400 x 300 x 350
7	2000A	1 x 6 x 200	400 x 300 x 375
8	2500A	2 x 6 x 125	400 x 350 x 425
9	3200A	2 x 6 x 150	400 x 400 x 450
10	4000A	2 x 6 x 200	400 x 450 x 550
11	5000A	3 x 6 x 200	400 x 500 x 600
12	6300A	3 x 6 x 230	400 x 600 x 650

VERTICAL TEE

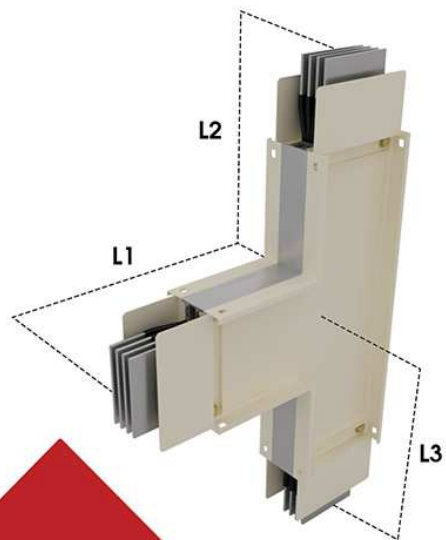

Item	Ampere (A)	Copper Size (mm)	Vertical Tee L1 (mm) x L2 (mm) x L3 (mm)
1	400A	1 x 6 x 30	300 x 300 x 300
2	630A	1 x 6 x 40	300 x 300 x 300
3	800A	1 x 6 x 50	300 x 300 x 300
4	1000A	1 x 6 x 75	325 x 325 x 325
5	1250A	1 x 6 x 80	325 x 325 x 325
6	1500A	1 x 6 x 100	325 x 325 x 325
7	1600A	1 x 6 x 125	350 x 350 x 350
8	2000A	1 x 6 x 150	350 x 350 x 350
9	2500A	1 x 6 x 200	375 x 375 x 375
10	3200A	2 x 6 x 125	425 x 425 x 425
11	4000A	2 x 6 x 150	450 x 450 x 450
12	5000A	2 x 6 x 200	550 x 550 x 550
13	5500A	3 x 6 x 150	550 x 550 x 550
14	6300A	3 x 6 x 160	600 x 600 x 600

Item	Ampere (A)	Aluminium Size (mm)	Vertical Tee L1 (mm) x L2 (mm) x L3 (mm)
1	400A	1 x 6 x 40	300 x 300 x 300
2	630A	1 x 6 x 50	300 x 300 x 300
3	800A	1 x 6 x 75	325 x 325 x 325
4	1000A	1 x 6 x 100	325 x 325 x 325
5	1250A	1 x 6 x 125	350 x 350 x 350
6	1600A	1 x 6 x 150	350 x 350 x 350
7	2000A	1 x 6 x 200	375 x 375 x 375
8	2500A	2 x 6 x 125	425 x 425 x 425
9	3200A	2 x 6 x 150	450 x 450 x 450
10	4000A	2 x 6 x 200	550 x 550 x 550
11	5000A	3 x 6 x 200	600 x 600 x 600
12	6300A	3 x 6 x 230	700 x 700 x 700

HORIZONTAL TEE

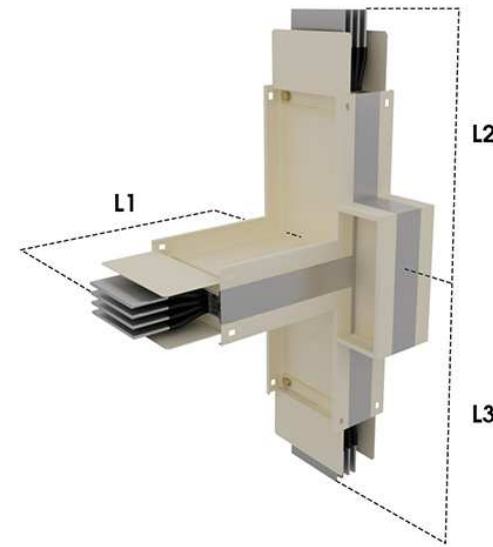

Item	Ampere (A)	Copper Size (mm)	Horizontal Tee L1 (mm) x L2 (mm) x L3 (mm)
1	400A	1 x 6 x 30	400 x 400 x 400
2	630A	1 x 6 x 40	400 x 400 x 400
3	800A	1 x 6 x 50	400 x 400 x 400
4	1000A	1 x 6 x 75	400 x 400 x 400
5	1250A	1 x 6 x 80	400 x 400 x 400
6	1500A	1 x 6 x 100	400 x 400 x 400
7	1600A	1 x 6 x 125	400 x 400 x 400
8	2000A	1 x 6 x 150	400 x 400 x 400
9	2500A	1 x 6 x 200	400 x 400 x 400
10	3200A	2 x 6 x 125	500 x 500 x 500
11	4000A	2 x 6 x 150	500 x 500 x 500
12	5000A	2 x 6 x 200	500 x 500 x 500
13	5500A	3 x 6 x 150	500 x 500 x 500
14	6300A	3 x 6 x 160	500 x 500 x 500

Item	Ampere (A)	Aluminium Size (mm)	Horizontal Tee L1 (mm) x L2 (mm) x L3 (mm)
1	400A	1 x 6 x 40	400 x 400 x 400
2	630A	1 x 6 x 50	400 x 400 x 400
3	800A	1 x 6 x 75	400 x 400 x 400
4	1000A	1 x 6 x 100	400 x 400 x 400
5	1250A	1 x 6 x 125	400 x 400 x 400
6	1600A	1 x 6 x 150	400 x 400 x 400
7	2000A	1 x 6 x 200	400 x 400 x 400
8	2500A	2 x 6 x 125	500 x 500 x 500
9	3200A	2 x 6 x 150	500 x 500 x 500
10	4000A	2 x 6 x 200	500 x 500 x 500
11	5000A	3 x 6 x 200	500 x 500 x 500
12	6300A	3 x 6 x 230	500 x 500 x 500

VERTICAL OFFSET

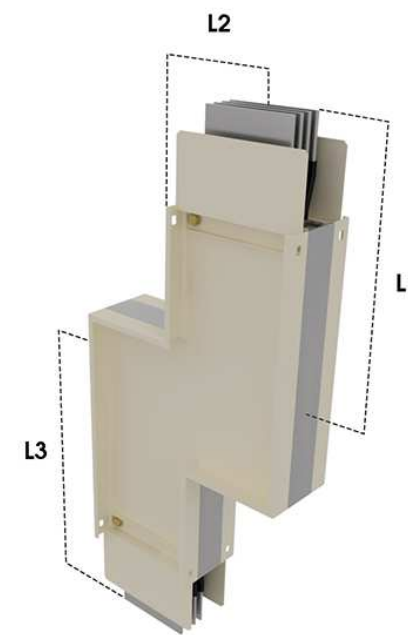

Item	Ampere (A)	Copper Size (mm)	Vertical Offset L1 (mm) x L2 (mm) x L3 (mm)
1	400A	1 x 6 x 30	300 x 250 x 300
2	630A	1 x 6 x 40	300 x 250 x 300
3	800A	1 x 6 x 50	300 x 250 x 300
4	1000A	1 x 6 x 75	325 x 250 x 325
5	1250A	1 x 6 x 80	325 x 250 x 325
6	1500A	1 x 6 x 100	325 x 250 x 325
7	1600A	1 x 6 x 125	350 x 250 x 350
8	2000A	1 x 6 x 150	350 x 250 x 350
9	2500A	1 x 6 x 200	375 x 250 x 375
10	3200A	2 x 6 x 125	425 x 250 x 425
11	4000A	2 x 6 x 150	450 x 250 x 450
12	5000A	2 x 6 x 200	450 x 250 x 500
13	5500A	3 x 6 x 150	550 x 250 x 550
14	6300A	3 x 6 x 160	600 x 250 x 600

Item	Ampere (A)	Aluminium Size (mm)	Vertical Offset L1 (mm) x L2 (mm) x L3 (mm)
1	400A	1 x 6 x 40	300 x 250 x 300
2	630A	1 x 6 x 50	300 x 250 x 300
3	800A	1 x 6 x 75	325 x 250 x 325
4	1000A	1 x 6 x 100	325 x 250 x 325
5	1250A	1 x 6 x 125	350 x 250 x 350
6	1600A	1 x 6 x 150	350 x 250 x 350
7	2000A	1 x 6 x 200	375 x 250 x 375
8	2500A	2 x 6 x 125	425 x 250 x 425
9	3200A	2 x 6 x 150	450 x 250 x 450
10	4000A	2 x 6 x 200	500 x 250 x 500
11	5000A	3 x 6 x 200	600 x 250 x 600
12	6300A	3 x 6 x 230	700 x 250 x 700

HORIZONTAL OFFSET

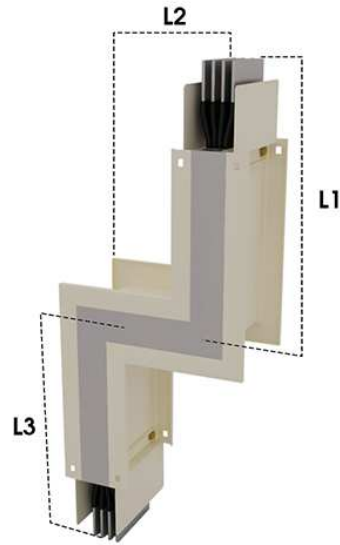

Item	Ampere (A)	Copper Size (mm)	Horizontal Offset L1 (mm) x L2 (mm) x L3 (mm)
1	400A	1 x 6 x 30	400 x 250 x 400
2	630A	1 x 6 x 40	400 x 250 x 400
3	800A	1 x 6 x 50	400 x 250 x 400
4	1000A	1 x 6 x 75	400 x 250 x 400
5	1250A	1 x 6 x 80	400 x 250 x 400
6	1500A	1 x 6 x 100	400 x 250 x 400
7	1600A	1 x 6 x 125	400 x 250 x 400
8	2000A	1 x 6 x 150	400 x 250 x 400
9	2500A	1 x 6 x 200	400 x 250 x 400
10	3200A	2 x 6 x 125	400 x 250 x 400
11	4000A	2 x 6 x 150	400 x 250 x 400
12	5000A	2 x 6 x 200	400 x 250 x 400
13	5500A	3 x 6 x 150	400 x 250 x 400
14	6300A	3 x 6 x 160	400 x 250 x 400

Item	Ampere (A)	Aluminium Size (mm)	Combination Elbow L1 (mm) x L2 (mm) x L3 (mm)
1	400A	1 x 6 x 40	400 x 250 x 400
2	630A	1 x 6 x 50	400 x 250 x 400
3	800A	1 x 6 x 75	400 x 250 x 400
4	1000A	1 x 6 x 100	400 x 250 x 400
5	1250A	1 x 6 x 125	400 x 250 x 400
6	1600A	1 x 6 x 150	400 x 250 x 400
7	2000A	1 x 6 x 200	400 x 250 x 400
8	2500A	2 x 6 x 125	400 x 250 x 400
9	3200A	2 x 6 x 150	400 x 250 x 400
10	4000A	2 x 6 x 200	400 x 250 x 400
11	5000A	3 x 6 x 200	400 x 250 x 400
12	6300A	3 x 6 x 230	400 x 250 x 400

REDUCER

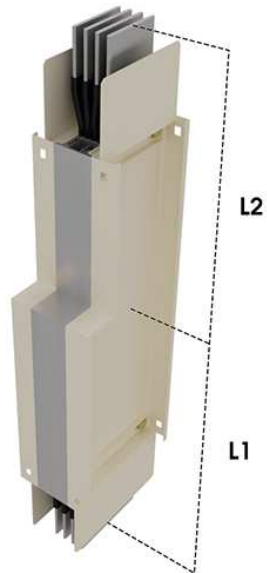

Item	Ampere (A)	Copper Size (mm)	Reducer	
			L1 (mm)	L2 (mm)
1	400A	1 x 6 x 30	500	500
2	630A	1 x 6 x 40	500	500
3	800A	1 x 6 x 50	500	500
4	1000A	1 x 6 x 75	500	500
5	1250A	1 x 6 x 80	500	500
6	1500A	1 x 6 x 100	500	500
7	1600A	1 x 6 x 125	500	500
8	2000A	1 x 6 x 150	500	500
9	2500A	1 x 6 x 200	500	500
10	3200A	2 x 6 x 125	600	600
11	4000A	2 x 6 x 150	600	600
12	5000A	2 x 6 x 200	600	600
13	5500A	3 x 6 x 150	600	600
14	6300A	3 x 6 x 160	600	600

Item	Ampere (A)	Aluminium Size (mm)	Reducer	
			L1 (mm)	L2 (mm)
1	400A	1 x 6 x 40	500	500
2	630A	1 x 6 x 50	500	500
3	800A	1 x 6 x 75	500	500
4	1000A	1 x 6 x 100	500	500
5	1250A	1 x 6 x 125	500	500
6	1600A	1 x 6 x 150	500	500
7	2000A	1 x 6 x 200	500	500
8	2500A	2 x 6 x 125	600	600
9	3200A	2 x 6 x 150	600	600
10	4000A	2 x 6 x 200	600	600
11	5000A	3 x 6 x 200	600	600
12	6300A	3 x 6 x 230	600	600

FLANGE END

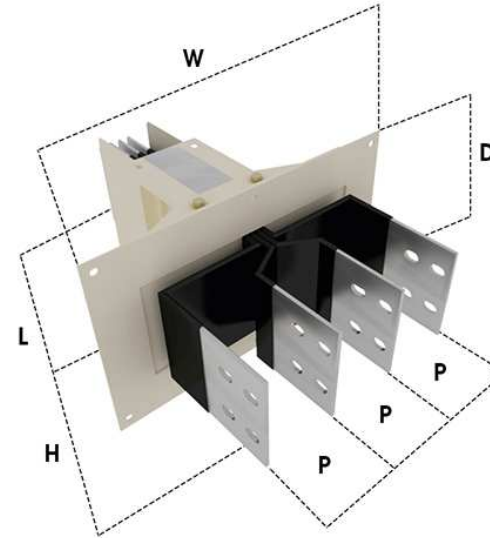

Item	Ampere (A)	Copper Size (mm)	Flange End				
			L(mm)	P(mm)	W(mm)	D(mm) H(mm)	
1	400A	1 x 6 x 30	350	100	450	155	200
2	630A	1 x 6 x 40	350	100	450	165	200
3	800A	1 x 6 x 50	350	100	450	175	200
4	1000A	1 x 6 x 75	350	100	450	200	200
5	1250A	1 x 6 x 80	350	100	450	205	200
6	1500A	1 x 6 x 100	350	100	450	225	200
7	1600A	1 x 6 x 125	350	100	450	250	200
8	2000A	1 x 6 x 150	350	100	450	275	200
9	2500A	1 x 6 x 200	350	100	450	325	200
10	3200A	2 x 6 x 125	350	130	540	395	200
11	4000A	2 x 6 x 150	350	130	540	445	200
12	5000A	2 x 6 x 200	350	130	540	545	200
13	5500A	3 x 6 x 150	350	130	540	615	200
14	6300A	3 x 6 x 160	350	130	540	645	200

Item	Ampere (A)	Aluminium Size (mm)	Flange End				
			L(mm)	P(mm)	W(mm)	D(mm) H(mm)	
1	400A	1 x 6 x 40	350	100	450	165	200
2	630A	1 x 6 x 50	350	100	450	175	200
3	800A	1 x 6 x 75	350	100	450	200	200
4	1000A	1 x 6 x 100	350	100	450	225	200
5	1250A	1 x 6 x 125	350	100	450	250	200
6	1600A	1 x 6 x 150	350	100	450	275	200
7	2000A	1 x 6 x 200	350	100	450	325	200
8	2500A	2 x 6 x 125	350	130	540	395	200
9	3200A	2 x 6 x 150	350	130	540	445	200
10	4000A	2 x 6 x 200	350	130	540	545	200
11	5000A	3 x 6 x 200	350	130	540	765	200
12	6300A	3 x 6 x 230	350	130	540	855	200

FLANGE END CONNECTION

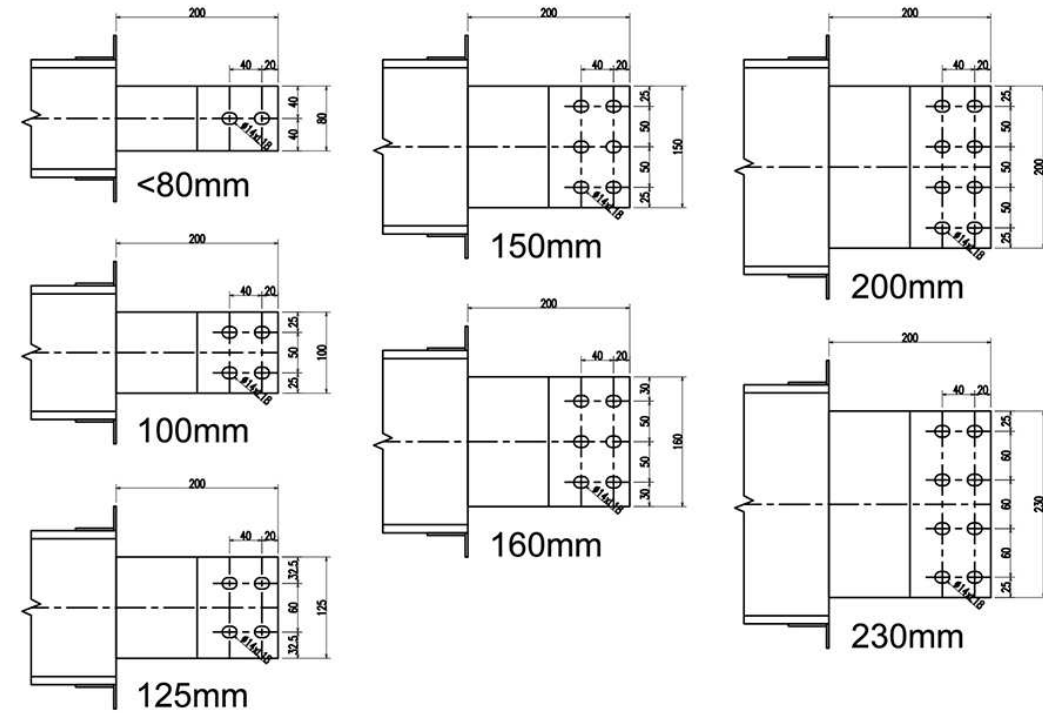

FLANGE END BOX

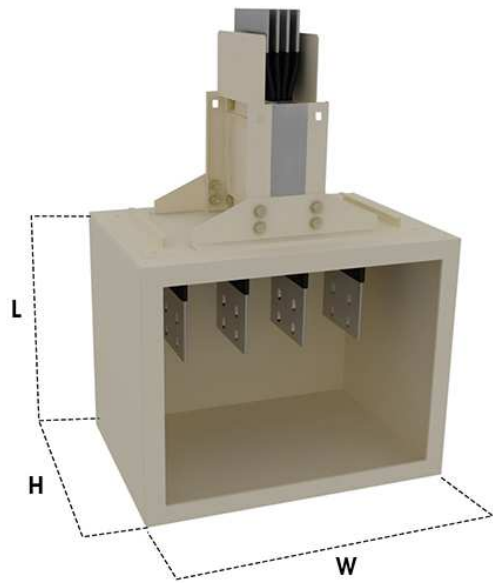

Item	Ampere (A)	Copper Size (mm)	Flange End Box		
			W(mm)	H(mm)	L(mm)
1	400A	1 x 6 x 30	500	195	500
2	630A	1 x 6 x 40	500	205	500
3	800A	1 x 6 x 50	500	215	500
4	1000A	1 x 6 x 75	500	240	500
5	1250A	1 x 6 x 80	500	245	500
6	1500A	1 x 6 x 100	500	265	500
7	1600A	1 x 6 x 125	500	290	500
8	2000A	1 x 6 x 150	500	315	500
9	2500A	1 x 6 x 200	500	365	500
10	3200A	2 x 6 x 125	590	435	500
11	4000A	2 x 6 x 150	590	485	500
12	5000A	2 x 6 x 200	590	585	500
13	5500A	3 x 6 x 150	590	655	500
14	6300A	3 x 6 x 160	590	685	500

Item	Ampere (A)	Aluminium Size (mm)	Flange End Box		
			W(mm)	H(mm)	L(mm)
1	400A	1 x 6 x 40	500	205	500
2	630A	1 x 6 x 50	500	215	500
3	800A	1 x 6 x 75	500	240	500
4	1000A	1 x 6 x 100	500	265	500
5	1250A	1 x 6 x 125	500	290	500
6	1600A	1 x 6 x 150	500	315	500
7	2000A	1 x 6 x 200	500	365	500
8	2500A	2 x 6 x 125	590	435	500
9	3200A	2 x 6 x 150	590	485	500
10	4000A	2 x 6 x 200	590	585	500
11	5000A	3 x 6 x 200	590	805	500
12	6300A	3 x 6 x 230	590	895	500

EXPANSION BOX

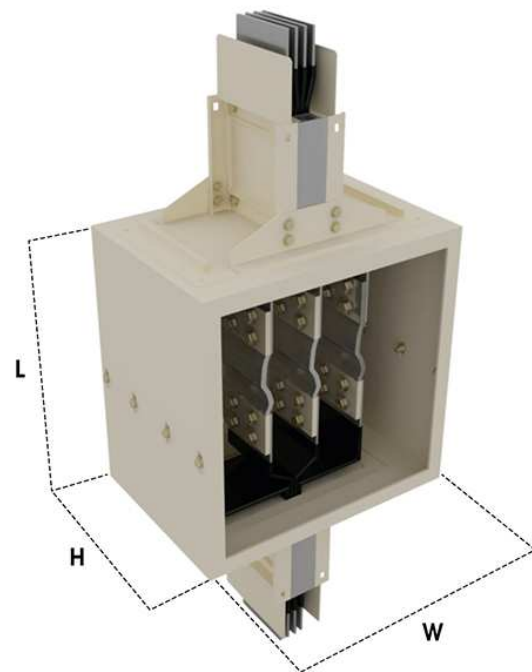

Item	Ampere (A)	Copper Size (mm)	Expansion Box		
			L(mm)	W(mm)	H(mm)
1	400A	1 x 6 x 30	570	500	195
2	630A	1 x 6 x 40	570	500	205
3	800A	1 x 6 x 50	570	500	215
4	1000A	1 x 6 x 75	570	500	240
5	1250A	1 x 6 x 80	570	500	245
6	1500A	1 x 6 x 100	570	500	265
7	1600A	1 x 6 x 125	570	500	290
8	2000A	1 x 6 x 150	570	500	315
9	2500A	1 x 6 x 200	570	500	365
10	3200A	2 x 6 x 125	570	590	435
11	4000A	2 x 6 x 150	570	590	485
12	5000A	2 x 6 x 200	570	590	585
13	5500A	3 x 6 x 150	570	590	655
14	6300A	3 x 6 x 160	570	590	685

Item	Ampere (A)	Aluminium Size (mm)	Expansion Box		
			L(mm)	W(mm)	H(mm)
1	400A	1 x 6 x 40	570	500	205
2	630A	1 x 6 x 50	570	500	215
3	800A	1 x 6 x 75	570	500	240
4	1000A	1 x 6 x 100	570	500	265
5	1250A	1 x 6 x 125	570	500	290
6	1600A	1 x 6 x 150	570	500	315
7	2000A	1 x 6 x 200	570	500	365
8	2500A	2 x 6 x 125	570	590	435
9	3200A	2 x 6 x 150	570	590	485
10	4000A	2 x 6 x 200	570	590	585
11	5000A	3 x 6 x 200	570	590	805
12	6300A	3 x 6 x 230	570	590	895

PLUG-IN BOX & TAP-OFF BOX

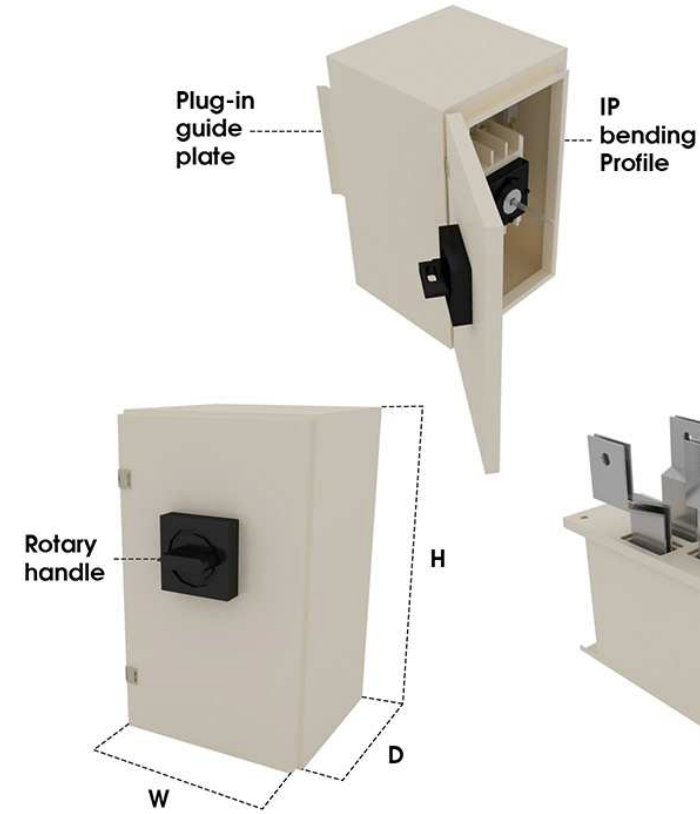

Item	Ampere (A)	Plug in Box		
		W(mm)	D(mm)	H(mm)
1	16A - 125A	250	220	420
2	150A - 250A	250	220	450
3	300A - 400A	350	320	600

Item	Ampere (A)	Tap Off Box		
		W(mm)	D(mm)	H(mm)
1	630A	350	250	900
2	800A	450	300	950
3	1000A	450	320	1050
4	1250A	450	320	1050
5	1600A	500	320	1200

WALL FLANGE

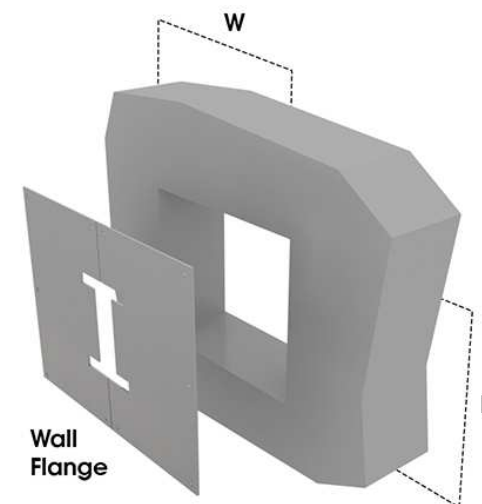

Item	Ampere (A)	Copper Size (mm)	Wall Flange	
			W(mm)	H(mm)
1	400A	1 x 6 x 30	200	195
2	630A	1 x 6 x 40	200	205
3	800A	1 x 6 x 50	200	215
4	1000A	1 x 6 x 75	200	240
5	1250A	1 x 6 x 80	200	245
6	1500A	1 x 6 x 100	200	265
7	1600A	1 x 6 x 125	200	290
8	2000A	1 x 6 x 150	200	315
9	2500A	1 x 6 x 200	200	365
10	3200A	2 x 6 x 125	200	435
11	4000A	2 x 6 x 150	200	485
12	5000A	2 x 6 x 200	200	585
13	5500A	3 x 6 x 150	200	655
14	6300A	3 x 6 x 160	200	685

Item	Ampere (A)	Aluminium Size (mm)	Wall Flange	
			W(mm)	H(mm)
1	400A	1 x 6 x 40	200	205
2	630A	1 x 6 x 50	200	215
3	800A	1 x 6 x 75	200	240
4	1000A	1 x 6 x 100	200	265
5	1250A	1 x 6 x 125	200	290
6	1600A	1 x 6 x 150	200	315
7	2000A	1 x 6 x 200	200	365
8	2500A	2 x 6 x 125	200	435
9	3200A	2 x 6 x 150	200	485
10	4000A	2 x 6 x 200	200	585
11	5000A	3 x 6 x 200	200	805
12	6300A	3 x 6 x 230	200	895

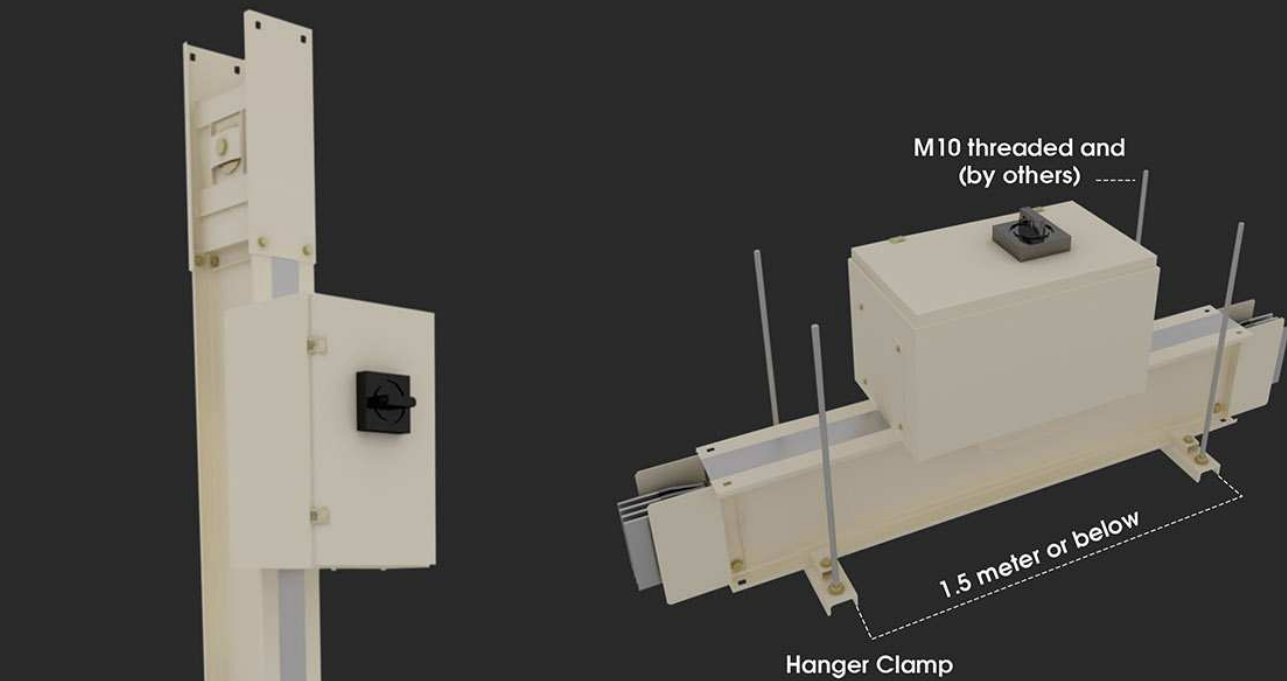

HORIZONTAL HANGER

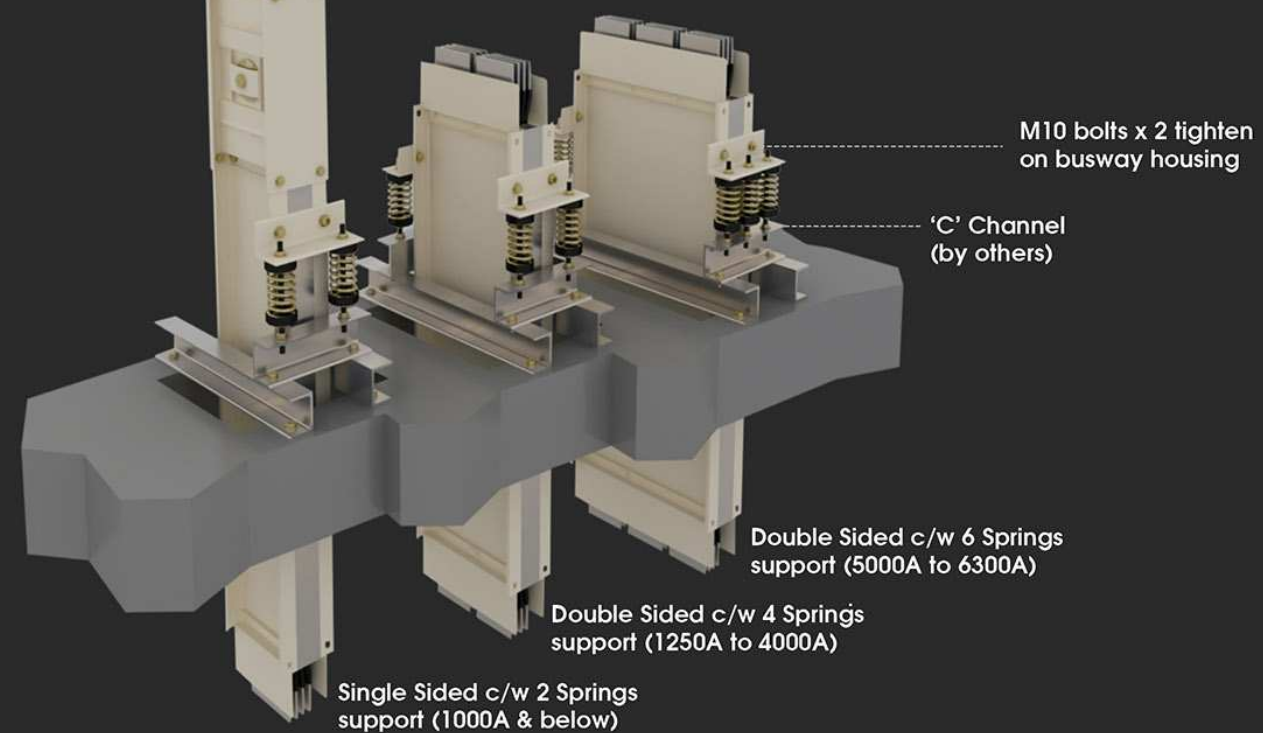

SPRING HANGER / FIXED HANGER

END CLOSURE

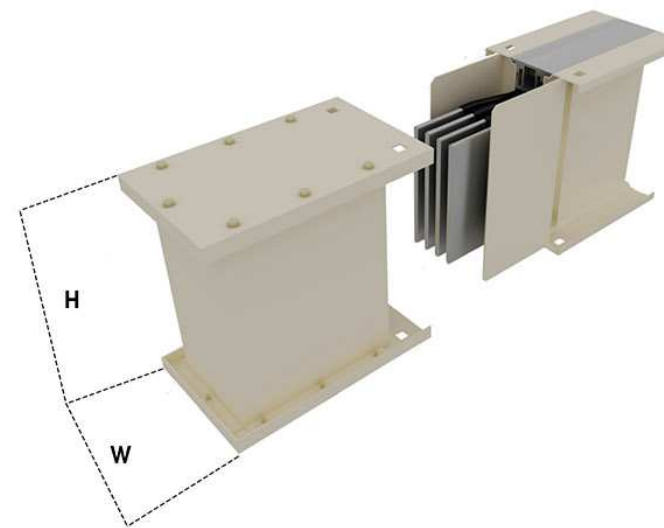

Item	Ampere (A)	Copper Size	End Closure (W) (H)	
1	400A	1 x 6 x 30	130	100
2	630A	1 x 6 x 40	130	110
3	800A	1 x 6 x 50	130	120
4	1000A	1 x 6 x 75	130	145
5	1250A	1 x 6 x 80	130	150
6	1500A	1 x 6 x 100	130	170
7	1600A	1 x 6 x 125	130	195
8	2000A	1 x 6 x 150	130	220
9	2500A	1 x 6 x 200	130	270
10	3200A	2 x 6 x 125	130	340
11	4000A	2 x 6 x 150	130	390
12	5000A	2 x 6 x 200	130	490
13	5500A	3 x 6 x 150	130	560
14	6300A	3 x 6 x 160	130	590

Item	Ampere (A)	Aluminium Size	End Closure (W) (H)	
1	400A	1 x 6 x 40	130	110
2	630A	1 x 6 x 50	130	120
3	800A	1 x 6 x 75	130	145
4	1000A	1 x 6 x 100	130	170
5	1250A	1 x 6 x 125	130	195
6	1600A	1 x 6 x 150	130	220
7	2000A	1 x 6 x 200	130	270
8	2500A	2 x 6 x 125	130	340
9	3200A	2 x 6 x 150	130	390
10	4000A	2 x 6 x 200	130	490
11	5000A	3 x 6 x 200	130	710
12	6300A	3 x 6 x 230	130	800

FLEXIBLE CONDUCTOR

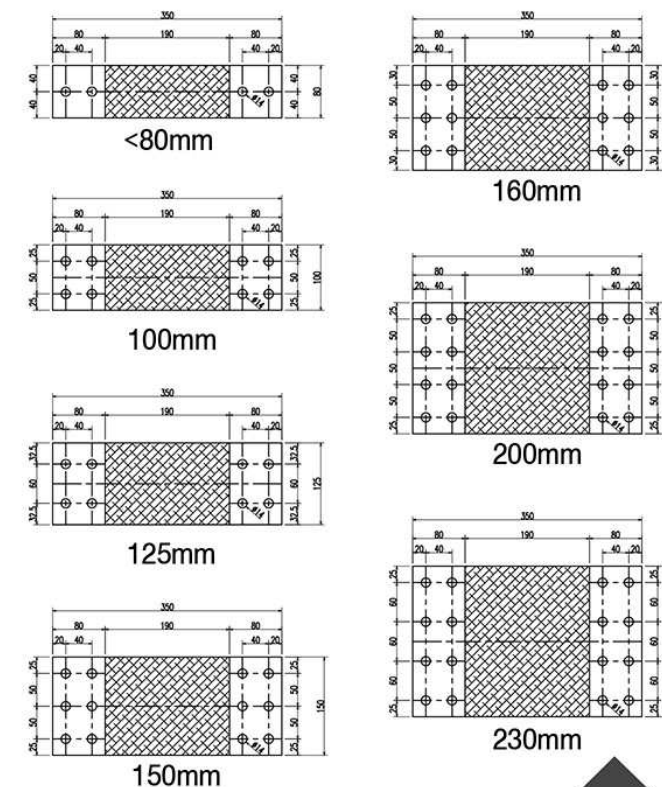

Item	Ampere (A)	Copper Size (W)
1	400A	1 x 30
2	630A	1 x 40
3	800A	1 x 50
4	1000A	1 x 75
5	1250A	1 x 80
6	1500A	1 x 100
7	1600A	1 x 125
8	2000A	1 x 150
9	2500A	1 x 200
10	3200A	2 x 125
11	4000A	2 x 150
12	5000A	2 x 200
13	5500A	3 x 150
14	6300A	3 x 160

Item	Ampere (A)	Aluminium Size (W)
1	400A	1 x 40
2	630A	1 x 50
3	800A	1 x 75
4	1000A	1 x 100
5	1250A	1 x 125
6	1600A	1 x 150
7	2000A	1 x 200
8	2500A	2 x 125
9	3200A	2 x 150
10	4000A	2 x 200
11	5000A	3 x 200
12	6300A	3 x 230

ELECTRICAL CHARACTERISTICS COPPER CONDUCTOR

Frequency 50Hz

Rated Current (AMP)	No. of Bar Phase	Busbar Size (mm)	Impedance (10 ⁻⁵ ohm/m)			Line to Line Voltage Drop V _d /100M at Rated Current and at Various Power Factor			
			R	X	Z	1.00	0.90	0.85	0.80
400	1	6 x 30	10.39	4.49	11.32	7.20	7.83	7.75	7.62
630	1	6 x 40	9.42	3.88	10.18	10.27	11.09	10.96	10.76
800	1	6 x 50	8.24	2.79	8.70	11.42	11.96	11.74	11.46
1000	1	6 x 75	5.37	2.22	5.81	9.30	10.05	9.93	9.75
1250	1	6 x 80	4.62	2.03	5.05	10.00	10.92	10.82	10.64
1500	1	6 x 100	4.03	1.85	4.43	10.46	11.52	11.43	11.26
1600	1	6 x 125	3.22	1.26	3.46	8.93	9.55	9.42	9.23
2000	1	6 x 150	2.69	0.77	2.79	9.30	9.54	9.31	9.04
2500	1	6 x 200	1.99	0.73	2.12	8.64	9.14	9.00	8.80
3200	2	6 x 125	1.61	0.63	1.73	8.93	9.55	9.42	9.23
4000	2	6 x 150	1.34	0.39	1.40	9.30	9.54	9.31	9.04
5000	2	6 x 200	1.00	0.36	1.06	8.64	9.14	8.80	8.29
5500	3	6 x 150	0.90	0.26	0.93	8.53	8.74	8.29	7.72
6300	3	6 x 160	0.67	0.21	0.70	7.31	7.58	7.42	7.22

Frequency 60Hz

Rated Current (AMP)	No. of Bar Phase	Busbar Size (mm)	Impedance (10 ⁻⁵ ohm/m)			Line to Line Voltage Drop V _d /100M at Rated Current and at Various Power Factor			
			R	X	Z	1.00	0.90	0.85	0.80
400	1	6 x 30	10.58	7.15	12.77	7.33	8.76	8.84	8.84
630	1	6 x 40	9.28	5.16	10.62	10.13	11.57	11.58	11.48
800	1	6 x 50	7.74	3.39	8.45	10.72	11.70	11.59	11.39
1000	1	6 x 75	5.64	2.60	6.21	9.77	10.75	10.67	10.51
1250	1	6 x 80	4.97	2.21	5.44	10.76	11.77	11.67	11.48
1500	1	6 x 100	4.25	1.97	4.69	11.04	12.17	12.08	11.91
1600	1	6 x 125	3.40	1.59	3.76	9.43	10.41	10.34	10.19
2000	1	6 x 150	2.83	1.30	3.12	9.82	10.80	10.72	10.55
2500	1	6 x 200	2.11	1.05	2.35	9.12	10.18	10.14	10.02
3200	2	6 x 125	1.70	0.80	1.88	9.43	10.41	10.34	10.19
4000	2	6 x 150	1.42	0.65	1.56	9.82	10.80	10.72	10.55
5000	2	6 x 200	1.05	0.52	1.18	9.12	10.18	10.02	9.62
5500	3	6 x 150	0.94	0.45	1.05	9.00	9.97	9.77	9.36
6300	3	6 x 160	0.63	0.35	0.72	6.87	7.85	7.86	7.79

ALUMINIUM CONDUCTOR

Frequency 50Hz

Rated Current (AMP)	No. of Bar Phase	Busbar Size (mm)	Impedance (10 ⁻⁵ ohm/m)			Line to Line Voltage Drop V _d /100M at Rated Current and at Various Power Factor			
			R	X	Z	1.00	0.90	0.85	0.80
400	1	6 x 40	13.97	3.48	14.40	9.68	0.76	9.50	9.19
600	1	6 x 50	11.21	2.61	11.65	11.67	11.33	11.33	10.95
800	1	6 x 75	8.95	1.83	9.13	12.40	12.26	11.87	11.44
1000	1	6 x 100	5.97	1.43	6.13	10.33	10.38	10.08	9.75
1250	1	6 x 125	4.31	1.34	4.51	9.32	9.66	9.45	9.20
1600	1	6 x 150	3.25	1.06	3.42	9.01	9.39	9.20	8.97
2000	1	6 x 200	2.72	0.83	2.84	9.41	9.72	9.51	9.25
2500	2	6 x 125	2.15	0.67	2.26	9.32	9.66	9.45	9.20
3200	2	6 x 150	1.63	0.53	1.71	9.01	9.39	9.20	8.97
4000	2	6 x 200	1.36	0.42	1.42	9.41	9.72	9.51	9.25
5000	3	6 x 200	1.08	0.35	1.14	9.38	9.78	9.59	9.34
6300	3	6 x 230	0.91	0.28	0.95	9.88	10.21	9.59	9.71

Frequency 60Hz

Rated Current (AMP)	No. of Bar Phase	Busbar Size (mm)	Impedance (10 ⁻⁵ ohm/m)			Line to Line Voltage Drop V _d /100M at Rated Current and at Various Power Factor			
			R	X	Z	1.00	0.90	0.85	0.80
400	1	6 x 40	17.08	4.26	17.60	11.83	11.93	11.61	11.23
600	1	6 x 50	13.70	3.19	14.07	14.24	14.26	13.85	13.38
800	1	6 x 75	10.93	2.24	11.16	15.15	14.99	14.51	13.98
1000	1	6 x 100	7.29	2.14	7.60	12.63	12.98	12.69	12.33
1250	1	6 x 125	5.26	1.74	5.54	11.40	11.90	11.67	11.38
1600	1	6 x 150	4.12	1.49	4.38	11.42	12.08	11.88	11.61
2000	1	6 x 200	3.32	1.13	3.51	11.50	12.05	11.83	11.55
2500	2	6 x 125	2.63	0.87	2.77	11.40	11.90	11.67	11.38
3200	2	6 x 150	2.06	0.75	2.19	11.42	12.08	11.88	11.61
4000	2	6 x 200	1.66	0.57	1.75	11.50	12.05	11.83	11.55
5000	3	6 x 200	1.37	0.50	1.46	11.89	12.58	12.38	12.10
6300	3	6 x 230	1.11	0.38	1.17	12.07	12.66	12.43	12.12

MV BUSWAY TECHNICAL SPECIFICATION

Type of busway construction : NSPB
 Standard : IEC62271 & other equivalent standards
 System configuration : 3P3W & 3P3W+E
 Ingress of protection (IP) rating : IP54 to IP66
 Rated AC voltage : From 1kV to 36kV
 Frequency : 50Hz / 60Hz
 Current rating : Up to 6500A
 Conductor : Copper
 Service temperature : Up to 50°C
 (full load operation without de-rating)
 Short circuit capacity : 50kA

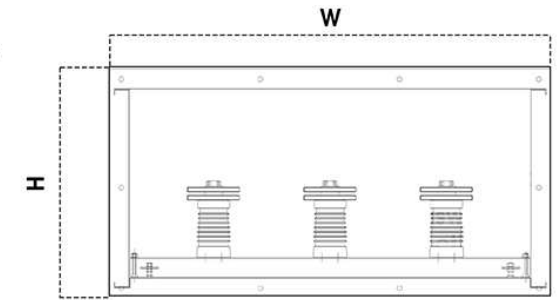

Item	Ampere (A)	3.6/7.2kV		12kV	
		W (mm)	H (mm)	W (mm)	H (mm)
1	630A	590	450	770	550
2	800A	590	450	770	550
3	1000A	665	450	845	550
4	1250A	710	450	890	550
5	1600A	770	450	950	550
6	2000A	710	450	890	550
7	2500A	810	450	950	550
8	3150A	1060	450	1150	550
9	4000A	1310	450	1400	550

Item	Ampere (A)	24kV		36kV	
		W (mm)	H (mm)	W (mm)	H (mm)
1	630A	1110	690	1610	920
2	800A	1110	690	1610	920
3	1000A	1185	690	1685	920
4	1250A	1230	690	1730	920
5	1600A	1290	690	1790	920
6	2000A	1230	690	1730	920
7	2500A	1290	690	1790	920
8	3150A	1440	690	1940	920
9	4000A	1590	690	2090	920

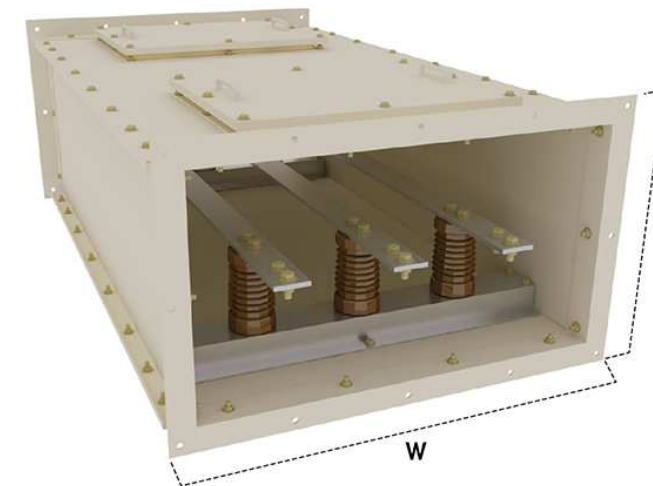

NSPB LV TYPE BUSWAY TECHNICAL SPECIFICATION

Type of busway construction : NSPB / AIR INSULATED
 Standard : IEC61439-6 & IEC62271
 System Configuration : 3P3W, 3P3W+E, 3P4W & 3P4W+E
 Ingress of protection (IP) rating : IP 54 to IP66
 Rated AC Voltage : Up to 3.6kV
 Frequency : 50 / 60Hz
 Current Rating : Up to 6500A
 Conductor : Copper
 Service temperature : Up to 50°C
 Short circuit capacity : 80kA

Item	Ampere (A)	W		H
		3W	4W	
1	630A	500	600	290
2	800A	500	600	290
3	1000A	500	600	315
4	1250A	500	600	330
5	1600A	500	600	350
6	2000A	500	600	330
7	2500A	500	600	350
8	3150A	500	600	400
9	4000A	500	600	450

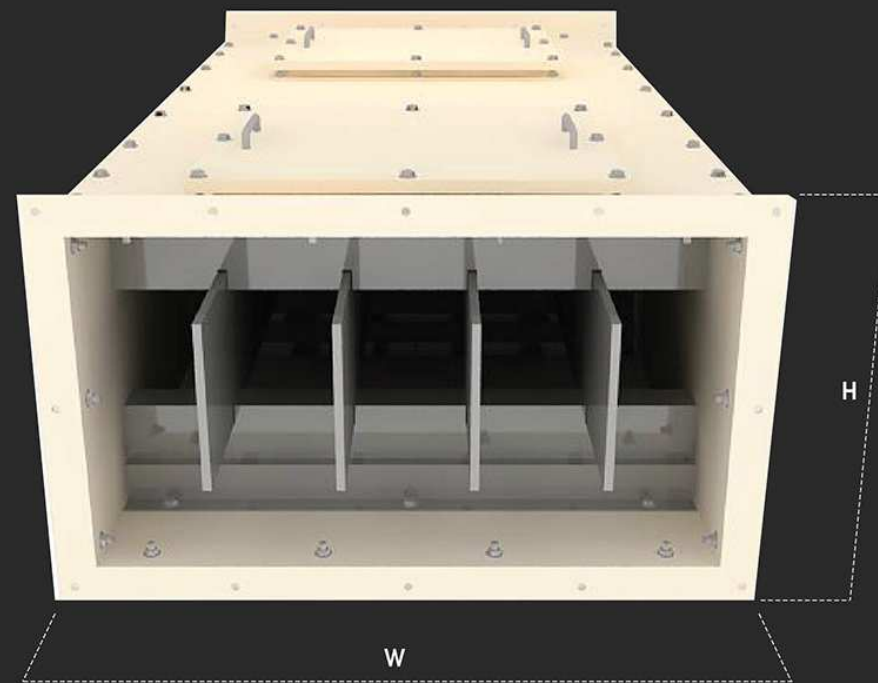
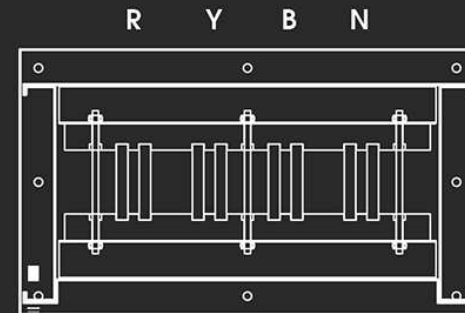

EPE Mini Busway

Ratings from 200A to 500A installs with minimum hardware and offer more advantages of power distribution by giving an alternative solution compare to traditional expensive cable and conduit installation. The lightweight aluminium housing design acts as an integral earth and heat sink, delivers impressive features and benefits for many types of industrial construction implementations.

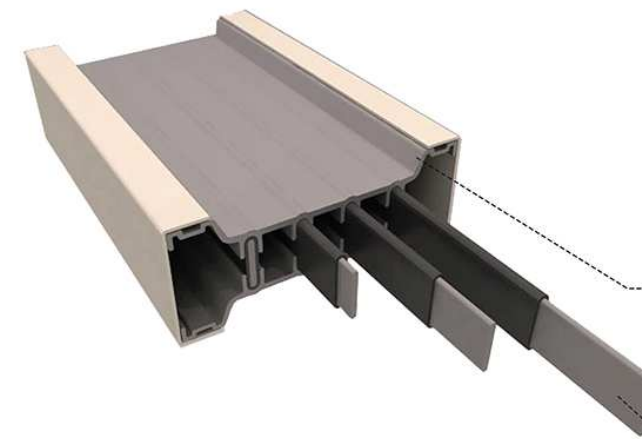

Item	Ampere (A)	Copper Size (mm)	W (mm)	H (mm)
1	200A	3 x 25	150	60
2	300A	3 x 25	150	60
3	400A	3 x 30	150	65
4	500A	3 x 40	150	75

Joint Connection Details

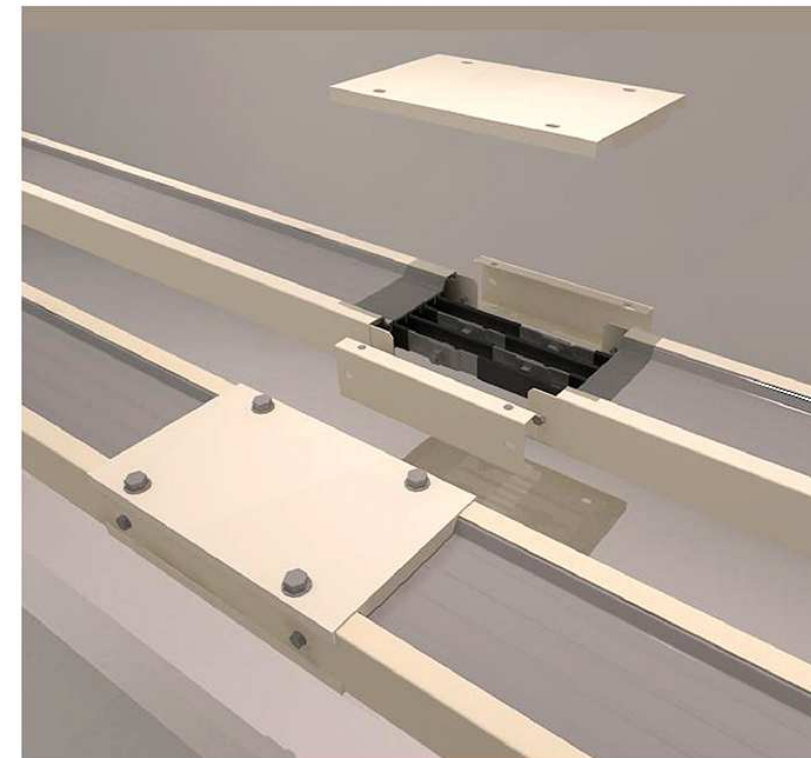

Plug-in Busway

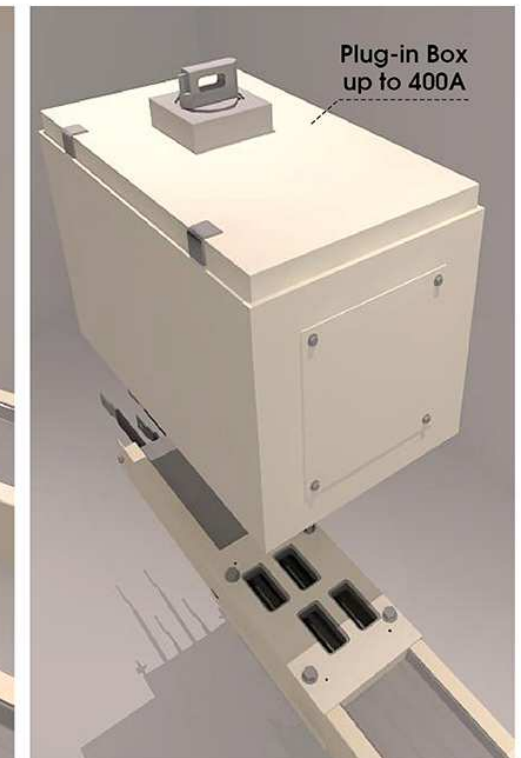

FIRE RATED BUSWAY

EPE Busway is designed and manufactured in accordance to BS6387 & IEC60331 standard. Fire temperature between 750 - 950 °C. Up to 3 hours.

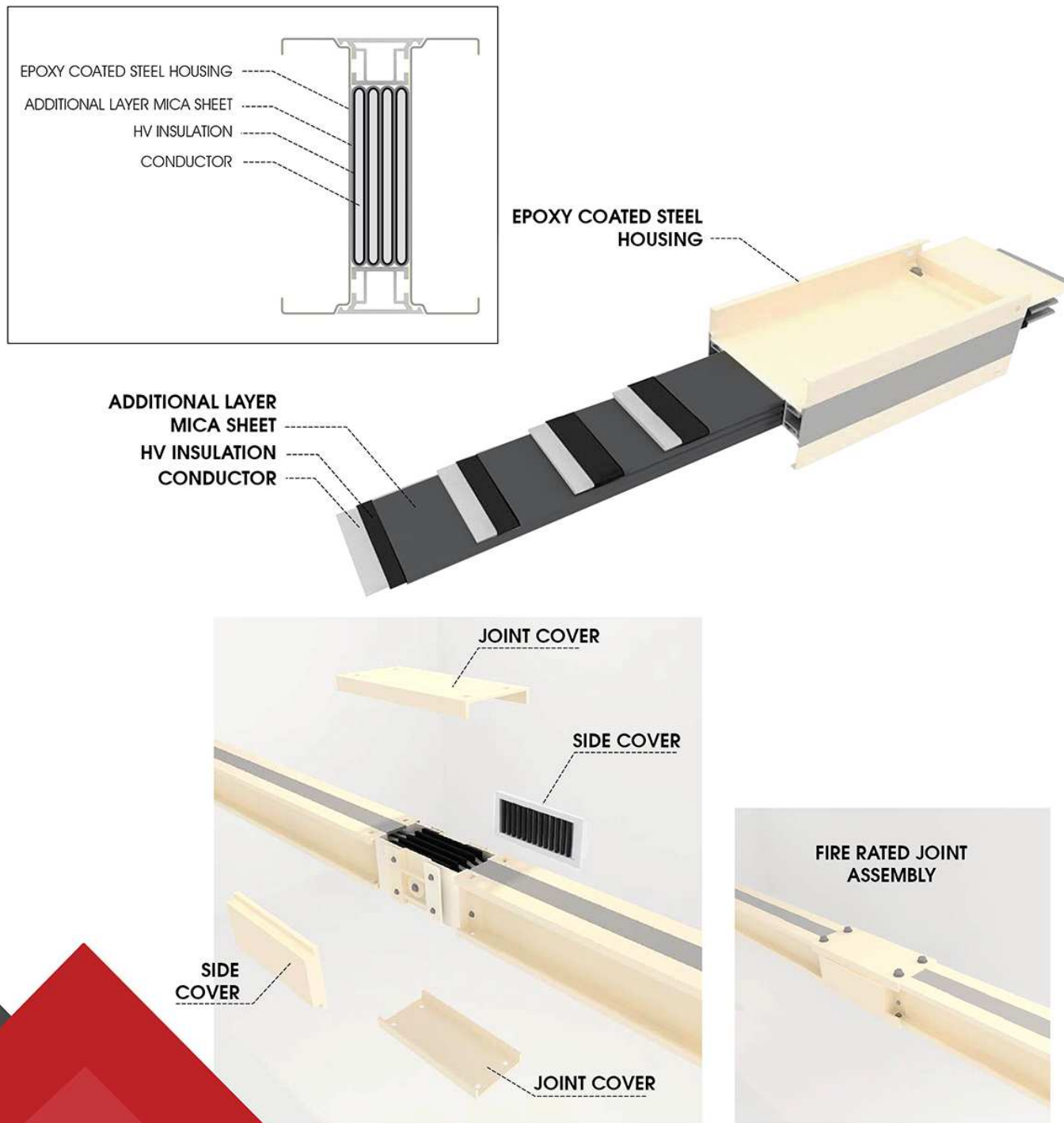

QUALITY ASSURANCE

Type tests are being carried out regularly by ASTA & UL, to comply required standards as well as customer requirements.

